

### DETALL 2

Planta

S1

Perfil metàl·lic

30

2ø16

Lb

ø16

1eø6c/10

ø16

S1

Lb=60cm

Voladur

ø16

ø16

4ø16 1eø6c/10

2ø16

Veure reforços en planta

FP-009c

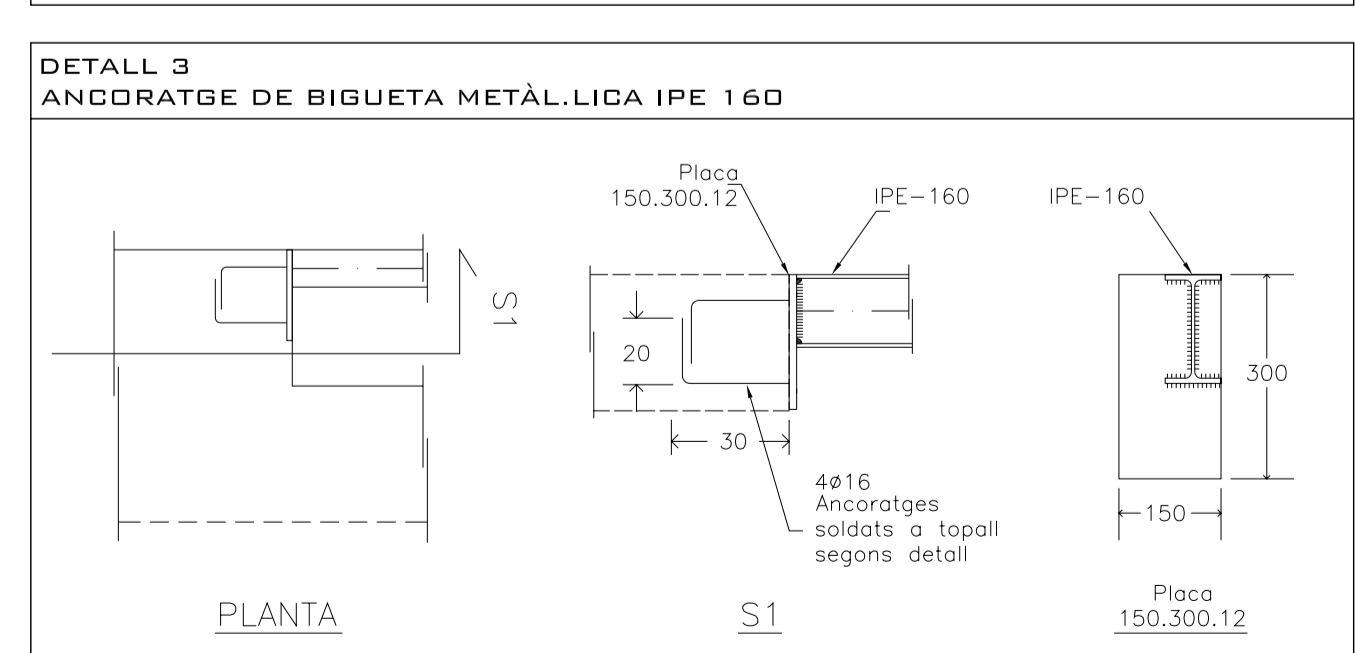

# E.A28

VISAT

projecte:	projecte executiu edifici d'equipaments Parc Central.	ref.	data
situació:	c/ Leonardo da Vinci 79-81 i c/ Diego de Almagro 42-46. Sabadell.	1078	setembre 2007
documentació	BLOC A. SP5 Detalls	escala	escala A3
		1/50	1/100

SAUQUET arquitectes i associats SL: X. Sauquet arquitecte R. Sauquet arquitecte

PROPIETAT: G. Bosch arquitecte associat

REVISIONS

data	revisió
Maig 2009	Revisat

S A U Q U E T  
a r q u i t e c t e s  
rambla 93, 2on 08202 SABADELL tel: 93 7259176 fax: 93 7259176 e-mail: sauquetarq@coac.net

**BIS** CONSULTORS BIS ARQUITECTES

ASSOCIACIÓ DE CONSULTORS DESTRUCTURALS

DIRECTOR TÈCNIC DAVID GARCIA, ARG.  
CAP D'EQUIP ESTHER MUÑOZ, ARG.  
RBLE. PROJECTES IVAN BALAGUÉ, ENG.